

Inductive Proximity Sensors

M50 | 30mm | PNP | NC | 300mA | 3 Wire

Ordering Code: D30C-5030-PB-3

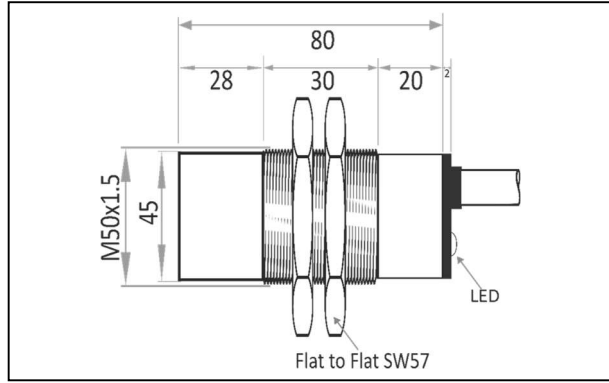

Technical Specifications

Cylindrical Metal Housing Diameter/Pitch (mm)	M50 / 1.5
Installation	Non-Flush
Rated Operating Distance (Sn)	30 mm
Actual Sensing Distance (Sa)	24.30 mm
Minimum Target size (min)	90 x 90 x 1 mm
Repeat Accuracy	≤ 10% mm
Hysteresis	≤ 15% of Sn
Operating Voltage	10 - 30 V DC
Residual Ripple (at operating Voltage)	≤ 10 %
Output Circuit Type	PNP NC
Max. Load Current (On state)	≤ 300 mA
Current Consumption (No Load)	< 13mA
Residual Current	< 0.6 mA
Switching Frequency	100 Hz
O/P status Indicator	Green LED
Voltage Drop	≤ 2.5V
Correction factor - Brass / Al	0.5 / 0.4
Operating Temperature Range	-10°C to 70°C
Temperature Drift	≤ 10% of Sn
Over load & Short circuit Protection	No
Reverse Polarity Protection	Yes
Environmental Protection	IP67
Rated Insulation Voltage	≤ 0.5 KV
Dielectric strength	1000VAC @ 50Hz – 1 min
Vibration resistance	10Hz – 55Hz, 1mm in X, Y & Z axis for 30 mins each
Shock resistance	30g for 1ms in X, Y & Z axis for 6 mins each
Insulation Class	□
Housing Material	Nickel Plated Brass

Electrical Connections

Termination

2 meter Prewired 3-Core PVC Cable (3 x 0.44mm²)

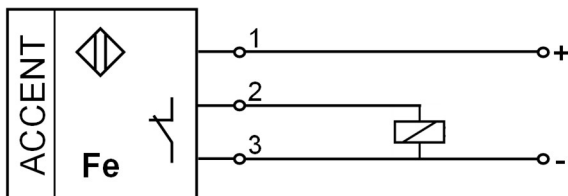

Wire Colour Coding:

1. RED : +
2. GREEN : Output
3. BLACK :-